



Myria Series

UPS 10-40kW

- » 3 level inverter and IGBT technology
- » Multi-functional touch screen
- » Adjustable input and output configuration
- » AC/AC efficiency up to 96%
- » Output power factor 1.0
- » High ambient temperature up to 50 °C
- » Integrated with input,output,bypass, maintenance bypass and battery breaker



Finance



Telecommunication



Data Center



Government



Energy



Medical



Transportation



Electricity

Myria Series UPS



High Reliability

- **Wide input voltage** range -60% ~ 25% and **wide input frequency** range 40-70Hz with high grid adaptability and prolong battery life.
- **Separate internal air channel** which hot air drives directly towards heat sink without distressing the PCB's and other internal sensitive components,improving components service life and UPS reliability.
- The most advanced and dual DSP control prevents single failure point and increase performance.
- **High overload capacity** on inverter for 105% load long run and 130% load 10 mins and bypass 130% load long run.
- Intelligent fan control and redundant design which make sure the radiation of internal circuit and maximum fan life time.
- **Integrated with 5 breakers** (input,output,bypass,maintenance bypass and battery breaker) for better system protection.
- **Standard conformal coating** to all PCB boards, protect electronics from environmental effecton and corrosion.
- **Standard dust filter** protect UPS placed in dusty environment.
- **Short circuit period time settable** from 20~200ms which provide high protection for system.
- **Lightning and surge protection** design which help UPS to sustain from high surge peak voltage.
- Local and remote EPO function NO/NC settable as standard for immediatly remove power from connected load in the event of emergency.
- **Input phase sequence correction** function allow UPS keep running in inverter mode without shifting to battery.
- Battery reverse connection protection to make sure the system reliability.
- Cold start function allow UPS start on battery when grid isn't available.
- Bus synchronization control function provides reliable high power for dual bus application.
- **Dual input** design which supports utility input and bypass input can be connected as single source or separated source.

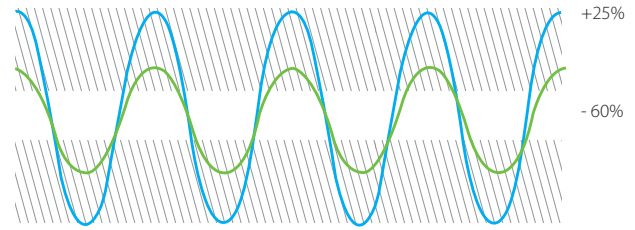

Wide Input Voltage



Automatic Fans Control

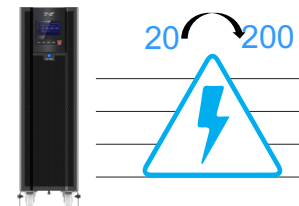

Short Circuit Time

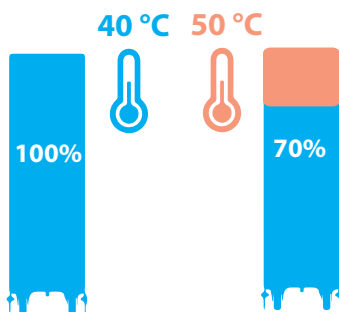

High Ambient Temperature

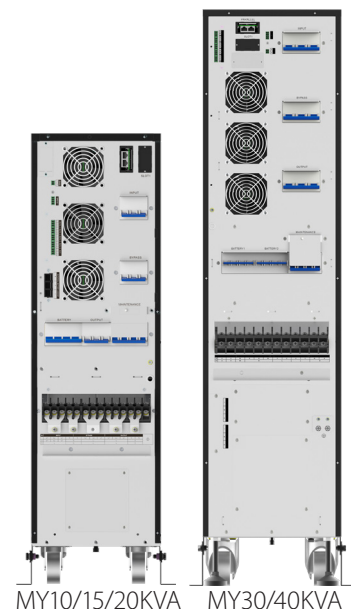



Green power

- **Latest generation IGBT and three level technology**, Low harmonic, high efficiency, effectively energy-saving.
- **High power density design**, which small footprint on 40KVA only 0.38m² for saving installation space.
- High input power factor up to 0.99 and **low Input THDi: < 3.0%** at full load, much less grid pollution and costs.
- **AC/AC efficiency up to 96%** and 25% load up to 94% efficiency reduces heat dissipation and limits power consumption costs.
- **ECO mode efficiency up to 99%** lead to significant cost reduction.
- **Self-load test function**, easy debugging and easy onsite test during commissioning, before it is connected the real load, without using costly temporary loads, cabling and breakers for energy saving.

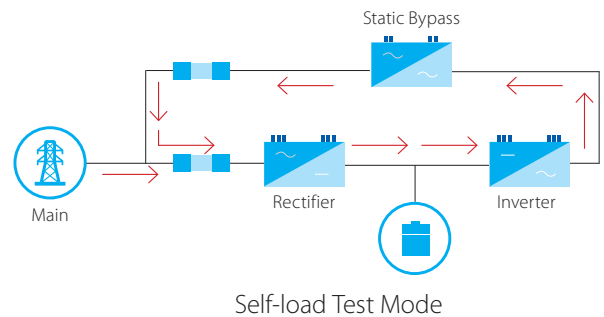
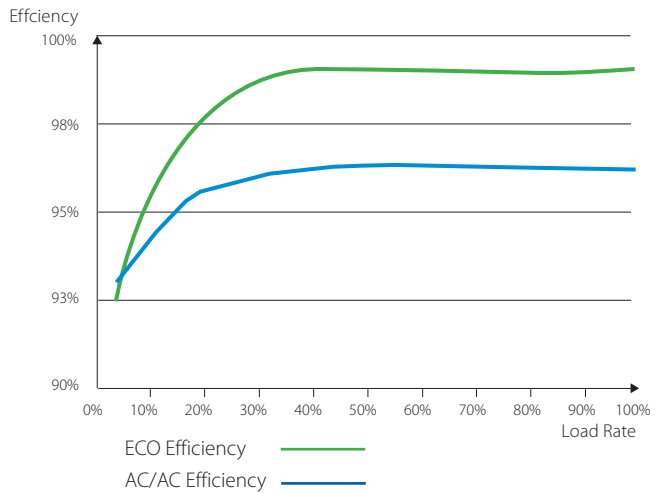

Flexibility Design

- **Adjustable input and output phase configuration** 3:3/3:1/1:1 for 10-20KVA and 3:3/3:1 for 30-40KVA with high flexibility to meet multiple power distribution condition (need jumper connector).
- **Integrated autonomy** with compact footprint and external battery slot for extend power outage, 10-20KVA could house up to 40 pcs battery and 30-40KVA could 80 pcs battery which **reduce installation cost**.
- **Optimize installation and easy service** architecture design minimizes the MTTR and optimizes serviceability and comes equipped with wheel which is easy for movement and relocation.
- **Parallel slot** design which allow up to 4 units parallel at site.
- **Full Galvanic Isolation**, isolation transformer can house inside the cabinet for full input or output isolation which suitable for medical and critical application; Internal sensor with temperature detection and alarm; Provide short circuit protection, restrain the high current puncture to UPS; no effects to the UPS output performance or reduced impact of the inverter power components whilst supplying specific loads.

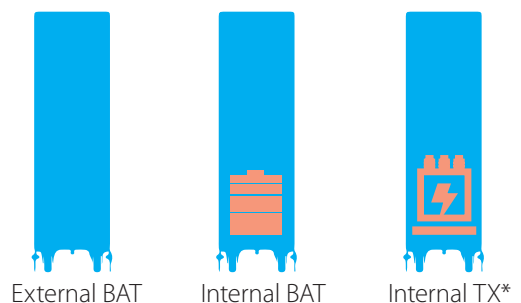
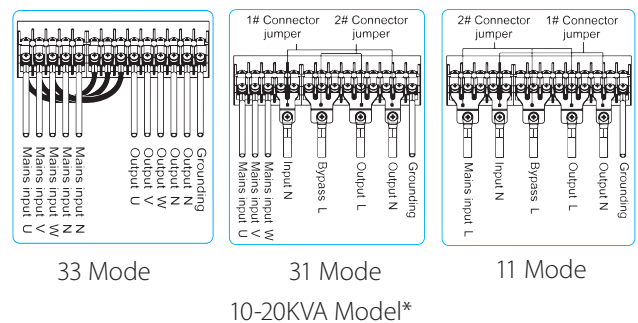

*Output TX for 3:3 and 3:1 different model

Myria Series UPS



Intelligent Management

- Multiple method of communication which provide RS485, dry contact, SNMP together with Modbus protocol to compatible with most management system.
- Smart programmable dry contact which have 1 input dry contact and 5 output dry contact, which input dry contact have more than 6 functions and output dry contact have 13 functions allows to settable at site.
- **Super wide DC voltage** range and settable from ± 96 to ± 240 (16~40 pcs) for 10KVA **no derating** and $\pm 144 \sim \pm 240$ for 20~40KVA (24~40 pcs).
- Intelligent battery charging with 3 stage methods prolong the service life of batteries.
- **Battery Static delay** function provide better battery care, to prevent overcharging when battery is full. Battery have slow self-discharge even if the battery does not discharge to the load, the battery voltage will slowly decrease. UPS could set duration for days to recharge the battery as full level to make sure **maximum life time**.
- **Key components pre-alarm** function which pre-alarm the system fault and remind service for key components, like capacitor, fan.
- **Input phase sequence correction** function allow UPS keep running in inverter mode without shifting to battery.
- **Self-dedusting** function with manual and period settable which allow technician set the time duration for UPS to clean the dust itself for saving the preventive service time.
- Common or distributed battery bank on parallel mode.
- Frequency converter function(60Hz to 50Hz or 50Hz to 60Hz)

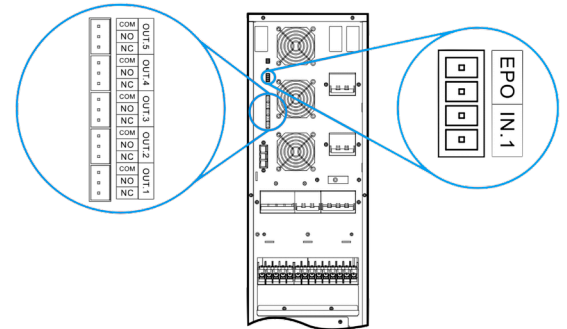

Programmable Dry Contact

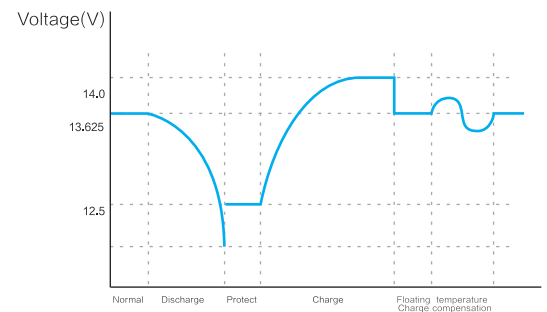

Intelligent Charging

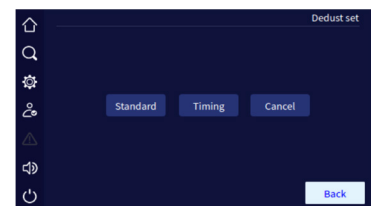

Self Dedust Function



Common Battery Bank



Frequency Converter Mode

User-friendly Interface

- Colorful **4.3 inches touch screen** with LED Indicators, ensure comprehensive and visualized information display.
- User-friendly double physical ON/OFF button design to avoid false operation.
- User-friendly graphical interface with single-line mimic diagram showing system status.
- Multi-language build-in display with Chinese, English, Spanish, Italian, French, Polish, Russian, Korean.
- High security access with separate password levels for users, technician and service engineers.
- Large data storage capacity, 10000pcs events logs.
- Easy update for display firmware.



4.3 inches Touch Screen

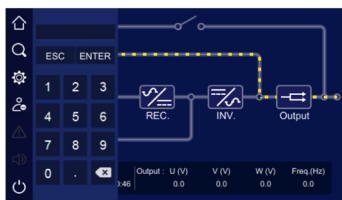

Different Level Password

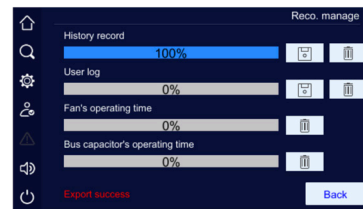

Record Management

More Options

- Parallel kit
- SNMP Kit
- Expanded dry contact kit
- BMS/Protocol transfer kit for lithium battery
- Dust filter kit
- Jumper connector for phase changing
- Intelligent Battery Monitoring System
- LCD display
- Input/output isolation transformer
- Battery Cabinet MY-BC
- Battery Charge Temperature Compensation Kit



Internal SNMP Kit



External SNMP Kit



BMS/Protocol transfer kit



Parallel kit



Battery Cabinet MY-BC



Expanded dry contact kit



Battery charge temperature compensation



Battery Monitoring System

Technical Specification

Capacity	10kW	15kW	20kW	30kW	40kW	
Input						
Phase	3:3/3:1/1:1			3:3/3:1		
Voltage (Vac)	80-280(L-N)/138-485 (L-L)			138-485 (L-L)		
Frequency (Hz)	40-70					
Power Factor	≥0.99					
THDi at full Linear load	<3%					
Output						
AC/AC Efficiency (Max.)	96%					
Power Factor	1.0					
Voltage (Vac)	220/230/240±1%(L-N) 380/400/415±1%(L-L)					
Frequency (Hz)	50/60±0.1 (battery mode)					
THDv	THD <1% (linear load), THD <3% (nonlinear load)					
Crest Factor	3:1					
Overload	3:3 Mode: 105% load long run, 110% load 60 mins, 130% load 10 mins, 155% load 1 min, above 155% load 200ms. 3:1 & 1:1 Mode: 105% load long run, 110% load 60 mins, 130% load 10 mins, 155% load 1s, above 155% load 200ms.					
Cold Start	Yes					
Battery						
Voltage (Vdc)	±96(±96 ~±240)	±192(±144 ~±240)*				
Internal Battery	16~40*9AH/12V	24~40*9AH/12V	48~80*9AH/12V			
Charging Current (A)	1-10 settable			1-20 settable		
Other						
Communication Interface	RS485+EPO+Dry Contact(1 input,5 output)+2 intelligent slots					
Display	4.3 Inches Touch Screen+ LED+ Physical buttons					
Alarm	Low battery, abnormal AC input, UPS failure, etc.					
Protection	Low battery, overload, short-circuit and over temperature, etc.					
Noise (dB)	<55					
Working Temperature (°C)*	-5~50, below 40 no derate, above 40 with linear derate.					
Relative Humidity	0 ~ 95%, no condensation					
Altitude(m)	2000, no derate					
Dimension (WxDxH)(mm)	250*755*880			300*785*1250		
UPS Weight (kg)	with Battery	95(16*9AH)	133.5(32*9AH)	133.5(32*9AH)	222(64*9AH)	222(64*9AH)
	w/o Battery	50	50	50	88.5	88.5
	with TX*	128	128	128	222	222
Battery Cabinet MY-BC						
Internal Battery	80*7/9AH 12V					
Dimension (WxDxH)(mm)	250*755*880					
Weight (kg)	50 (without battery)					

• Specification is subject to change without prior notice.

* Condition comply

Kehua Data Co., Ltd.

Add: No. 457, Malong Road, Torch High-Tech Industrial Zone, Xiamen Fujian China

Tel: +86-592-5160516 Fax: +86-592-5162166 www.kehua.com

Version No.: 20231001

